

PAPER • OPEN ACCESS

Development of Intelligent Agricultural Machinery Control Device

To cite this article: Ru Jiang *et al* 2020 *J. Phys.: Conf. Ser.* **1617** 012087

View the [article online](#) for updates and enhancements.



IOP | ebooks™

Bringing together innovative digital publishing with leading authors from the global scientific community.

Start exploring the collection—download the first chapter of every title for free.

Development of Intelligent Agricultural Machinery Control Device

Ru Jiang¹, Farkhod Kasimov¹, Dong Zhang^{1*} and Kulyash Kaliyeva²

¹ Institute of Automation, Qilu University of Technology (Shandong Academy of Sciences), Jinan, 250000, China

² Kazakh National Research Technical University, Almaty, 050000, Kazakhstan

*Corresponding author's e-mail: jnzd156@163.com

Abstract. This article is dedicated to creating a low-cost intelligent agricultural machinery control equipment based on ATmega 328p chip. The created control device is used to directly connect various peripheral sensors and actuators of the intelligent agricultural machinery to the computer. The controller circuit design diagram is given, and the control method is presented. The accuracy of the signal input/output channels of the control device to transmit signals was verified through experiments, and the control device was applied to the intelligent agricultural machinery experiment platform. The experimental results are analyzed and suggestions for further development of the control device are provided.

1. Introduction

With the acceleration of the urbanization process today, the rural labor force has declined sharply, and the intensification of farmland has gradually increased. Automation has become an important way for sustainable agricultural development.

As an integral part of the intelligent agricultural machinery control system, the importance of sensors becomes significant with the increasingly complex system function. However, normally sensors cannot connect to computer directly because of their own standards for signals. For example, some sensors give digital signal of 0-24V while other sensors give analogue signal in the range of 4-20mA or 0-10V. In this regard, to combine all signals into one control system, control box is required.

A large number of sensors are needed to complete the work in the intelligent agricultural machinery system, such as vision sensors, ultrasonic sensors, speed sensors, pressure sensors, etc. This article develops a low-cost universal control device based on the ATmega 328p chip for different output signals from different sensors in an intelligent agricultural machinery system. This control device has four digital inputs/outputs and four analogue signal inputs/outputs, and can meet the needs of the current intelligent agricultural system.

2. System hardware design

The sensors used in the intelligent agricultural system including radar, laser, ultrasonic and speed sensors, can detect light, heat, pressure or other variables used in the state of intelligent agricultural machinery. These sensors with agricultural machinery systems, computers and navigation systems together constitute the intelligent agricultural machinery.



The designed control device is based on the ATmega328p microcontroller and has compact dimensions. The ATmega328P is an 8-bit AVR microprocessor. It has high performance, low power consumption and advanced RISC structure. It can operate at speeds of up to 20 MHz and can meet the needs of intelligent agricultural data collection and communication. The ATmega328P has six channels of PWM, eight 10-bit ADCs and a programmable serial USART. Its pin structure is shown in Figure 1.

The circuit of control device is shown on figure 2. The circuit consists of ATmega328p microchip, photocouplers, transistors and MOSFETs. Optocouplers are used to protect the pins of microchip. Transistors are used to control high voltages in the output channels. The analogue outputs of the chip are considered as PWM.

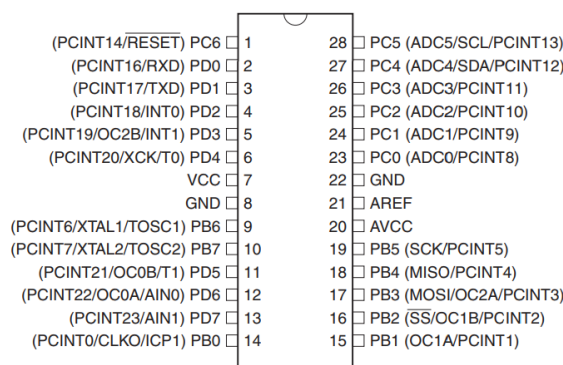

Figure 1. Pin structure of ATmega328P.

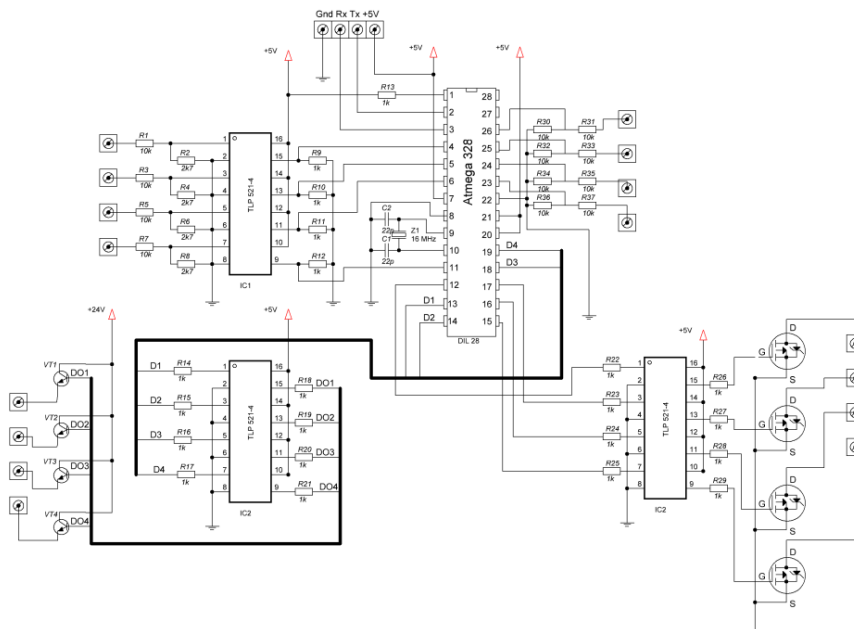

Figure 2. The circuit of control device

3. System software design

The software development for the control device of intelligent agricultural machinery simplified design method, combined with data structure algorithm, modular design and communication

procedures, and can achieve information sharing. The software development of the control device of agricultural machinery is developed by means of Arduino IDE software using C language. The software processing flow chart is shown in Figure 3.

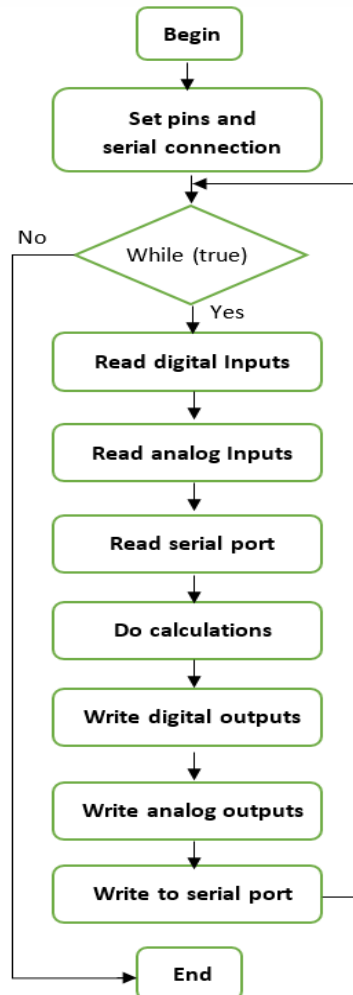

Figure 3. The software processing flow chart.

When the control device starts, it will first set the port function, establish a connection between the device and the computer and declare global variables. If the connection is normal, it will start working.

The controller can directly receive 0-24V digital signal input and 0-5V analog signal input, and carry out two-way communication with the computer through the serial port, the data exchange rate is up to 115200 baud.

4. Experiments

Some experiments are designed in order to test the function and accuracy of the control box.

4.1 Analogue input channel test

Experiment is conducted to check the accuracy of the analogue input channels. Different signals in the range from 0 to 5 volts are transmitted to the input channel of the microchip and the numerical value of the analogue input is measured. The results of experiment are shown as Table 1.

The comparison between the experimental results of the analogue input and the expected values is shown in Figure4 and Figure 5.

Table 1 Results of the analogue input channel

Voltage(V)	Measured value	Calculated value	Absolute error	Relative error (%)
0	0	0	0	0
0.5	100	102	2	1.96
1	202	205	3	1.46
1.5	303	307	4	1.30
2	404	409	5	1.22
2.5	507	512	5	0.98
3	607	614	7	1.14
3.5	709	716	7	0.98
4	817	818	1	0.12
4.5	918	921	3	0.32
5	1013	1023	10	0.987

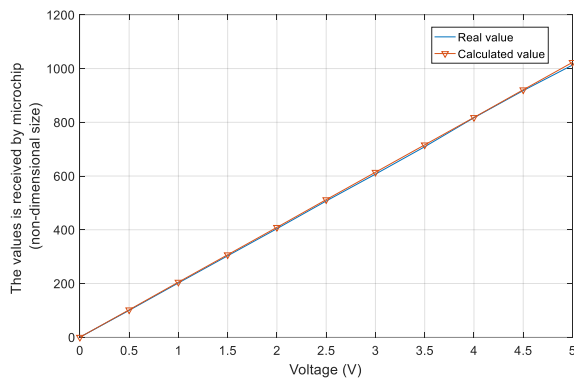

Figure 4. The input result comparison

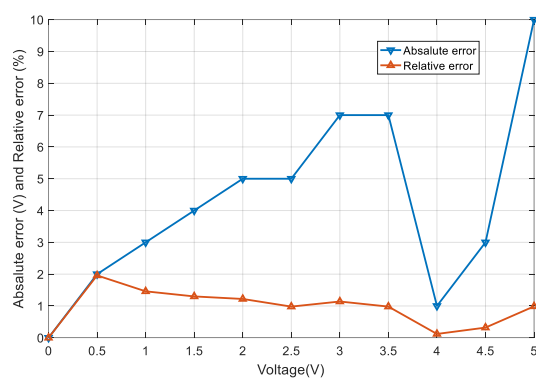

Figure 5. The error of input signal versus voltage

The graphs show that the experimental results and calculated values are very close. The maximum absolute error is at 5 V. It means that maximum error is 0.05 V. Typically, such errors are caused by an unstable voltage source. The performance of the control device can be improved by optimizing power supply stability.

4.2 Analogue output channel test

Experiment is conducted to evaluate the accuracy of analogue output channels. Different tasks in the range from 0 to 100% are sent to the device. The results of the experiment are shown as Table 2.

The comparison between the experimental results of the analogue output and the expected values is shown in Figure 6 and Figure 7.

As shown from the graphs, the analogue outputs value is close to calculated values. The maximum absolute error is at 20% which is -0.05V. This means that this control device has high precision and can be used in the control process.

Table 2 Results of the analogue output channel

Task(%)	Measured value (V)	Calculated value (V)	Absolute error (V)	Relative error(%)
0	0.00	0.00	0.00	0.00
10	0.54	0.50	-0.04	-8.00
20	1.05	1.00	-0.05	-5.00
30	1.54	1.50	-0.04	-2.67
40	2.04	2.00	-0.04	-2.00
50	2.53	2.50	-0.03	-1.20

60	3.04	3.00	-0.04	-1.33
70	3.53	3.50	-0.03	-0.86
80	4.03	4.00	-0.03	-0.75
90	4.52	4.50	-0.02	-0.44
100	4.99	5.00	0.01	0.20

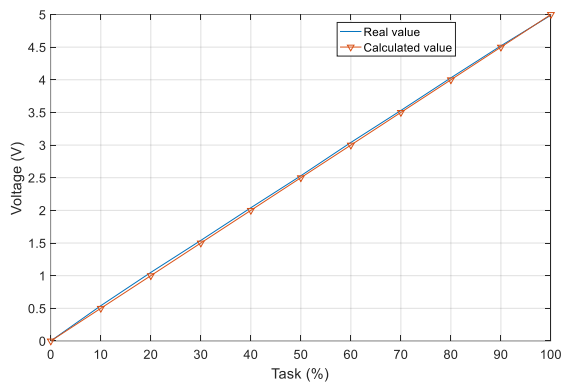

Figure 6. The output result comparison

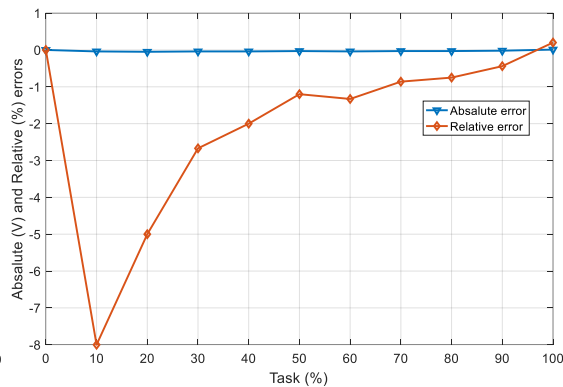

Figure 7. The error of output signal versus voltage

4.3 Test on unmanned agricultural machinery

We modified the agricultural machinery platform, and the completed experimental platform is shown in Figure 8. The experimental platform is equipped with this control device, which reads sensor parameters such as speed and steering angle, and assists in completing the unmanned pilot test. The comparison between experimental measured path and planned path is shown in Figure 9. The experimental results show that the unmanned agricultural machinery can complete the task of tracking planned path well. The maximum lateral deviation of the straight path tracking is about 4cm.



Figure 8. The experimental platform

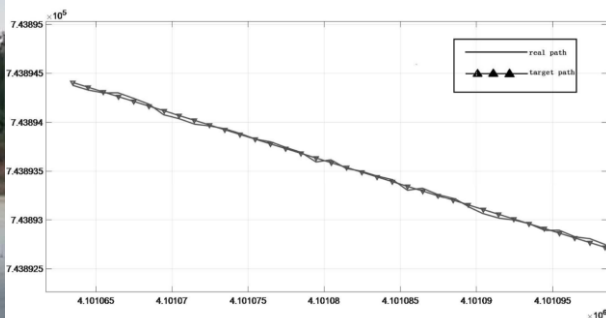

Figure 9. Comparison of real path and target path

5. Conclusions

Intelligent agricultural machinery can greatly improve the efficiency of farmland operation, complete large-scale farmland coverage with very little manpower, save agricultural input costs and increase farmers' economic benefits.

In this article, the control device can be used for intelligent agricultural machinery. This control device has the characteristics of low cost, high precision and fast response. In the future, it is convenient to carry a variety of other function chips, so that the function of this control box can be quickly added to fulfil different needs.

Acknowledgments

This work was financially supported by the Shandong Academy of Sciences International Science and Technology Cooperation Project (2019GHPY22), and Shandong Academy of Sciences-Lanshan District Industry-University-Research Collaborative Innovation Fund Project.

References

- [1] Dong Sheng, Yuan Chaohui, Gu Chao.(2017). A survey of research on intelligent agricultural machinery control platform based on multidisciplinary technology fusion. *Journal of Agricultural Engineering*, 33(8),1-11.
- [2] Kitchen N R, Snyder C J, Franzen D W, Wiebole W J. (2002).Educational needs of precision agriculture. *Precision Agriculture*, 3(2),341-351.
- [3] Li Jun, Ma Rong. (2011). Tractor automatic navigation technology based on multi-sensor fusion *Agricultural Mechanization Research*, 33(12), 58-60.
- [4] Naiqian Zhang, Maohua Wang, Ning Wang.(2002) Precision agriculture—a worldwide overview. *Computers and Electronics in Agriculture*, 36(2),113-132.
- [5] P. Dangare,T. Mhizha,E. Mashonjowa.(2018). Design, fabrication and testing of a low cost Trunk Diameter Variation (TDV) measurement system based on an ATmega 328/P microcontroller. *Computers and Electronics in Agriculture*, 148,197-206.
- [6] Thomas Noulis.(2015). *Mixed-Signal Circuits*. Taylor and Francis, England.
- [7] Sherif Hekal, Ahmed Allam, Adel B. Abdel-Rahman, Ramesh K. Pokharel.(2019). *Design Methods*.Springer, Singapore.
- [8] Sun Jie. (2017) “13th five-year national science and technology innovation plan”: Optimize the innovation of agricultural and rural areas. *Chinese Rural Technology*,12, 10
- [9] Yongwei Tang. (2017). Research and Application of Intelligent Control of Agricultural Machinery Based on Hardware and Software Collaborative Design. *Proceedings of 2017 IEEE 3rd Information Technology and Mechatronics Engineering Conference(ITOEC 2017)*,p1113-1116.
- [10] Zhang Q. (2003). A generic fiizzy electrohydraulic steering controller for off-road vehicles. *Automobile Engineering*,217,791-799.